

INSTALLATION INSTRUCTIONS FOR BOLT ON GUARDIAN MOTOR SUPPORT

1. After removing your Springfield Marine Guardian Motor Support from its packaging pull out the safety pin (FIG1, 1) and remove the bolt on "T" brace (FIG1, 2).
2. Bolt the "T" brace to the bottom cross support at the back of your trailer using bolts and nuts (not included). Locate the "T" brace in the center of the support in line with the center of the lower unit.
3. Extra holes may be required to mount the "T" brace. Refer to the diagram below for the pattern required.
4. Remove the bolt and nut that secure the inner support tube to the outer support tube (FIG1, 3). Place the inner tube of the Motor Support over the "T" brace and reinsert safety pin.
5. Place the "Y" shaped support yoke (FIG1, 4) so that the composite pads rest against the lower unit. Line up holes in the inner and outer support tubes and reinstall the bolt and nut.
6. Verify that the Motor Support is perpendicular to the trailer brace and resting in an area that will not damage the lower unit.
6. With hands free from pinch points trim the motor down until the motor is supported and the motor support is secure.

Guardian Motor Support is for trailering and storage only, remove before attempting to untrailer the boat. Springfield Marine is not liable for product failure or damage to boat, motor, or trailer due to improper installation or use.

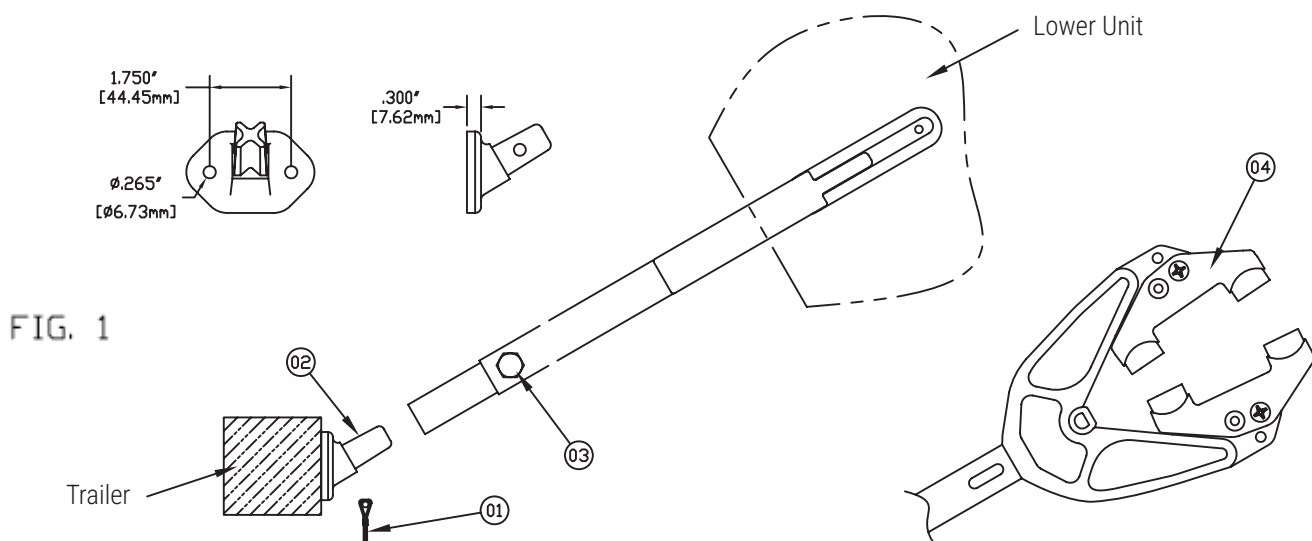

FIG. 1